

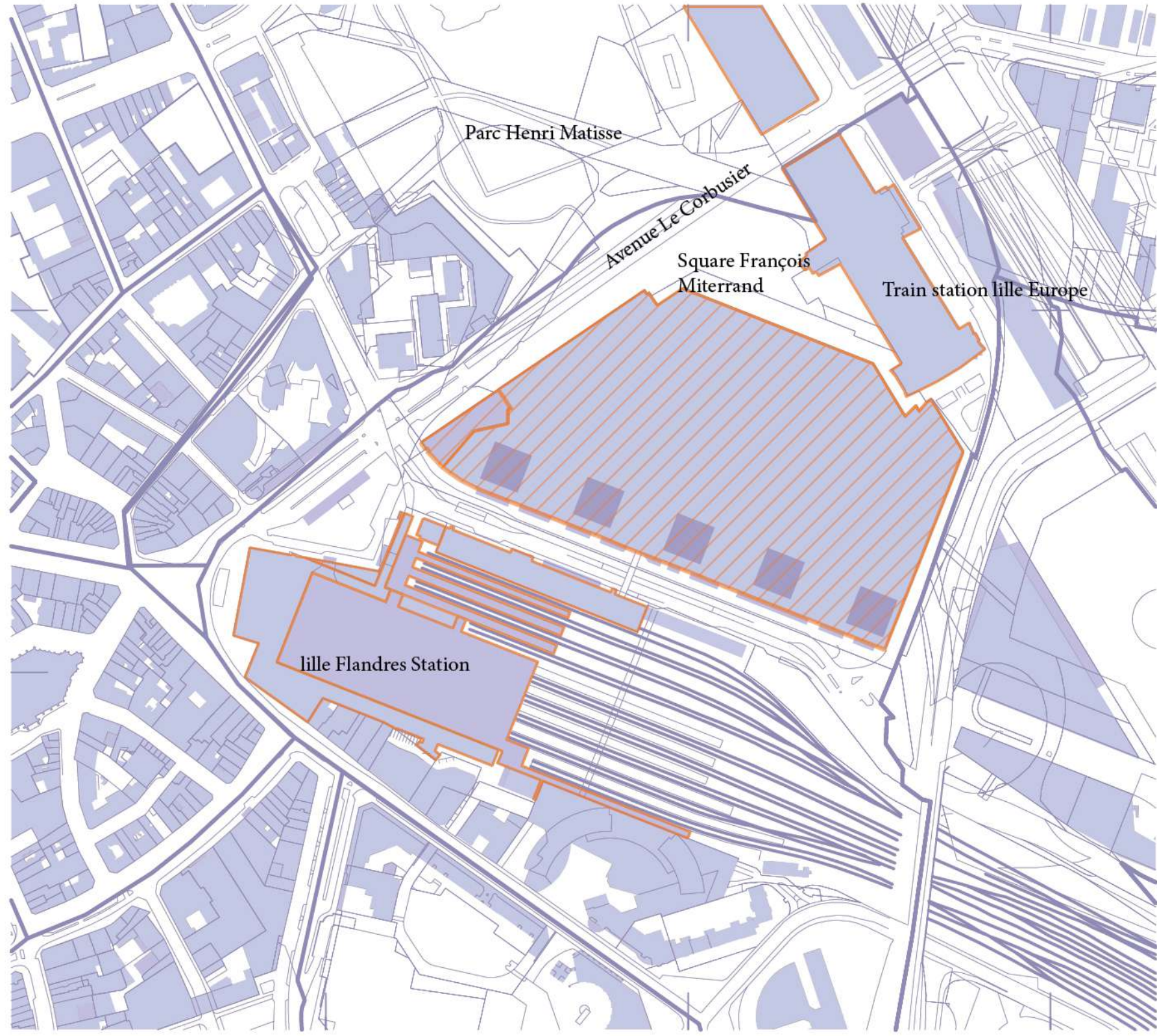

Atom Architecture
Lille, France
Team leader
Denitsa Hristova, France
Team members
Inès Dekeister, France

FROM SMALL-SCALE INNOVATION TO URBAN TRANSFORMATION

From small-scale innovation to urban transformation

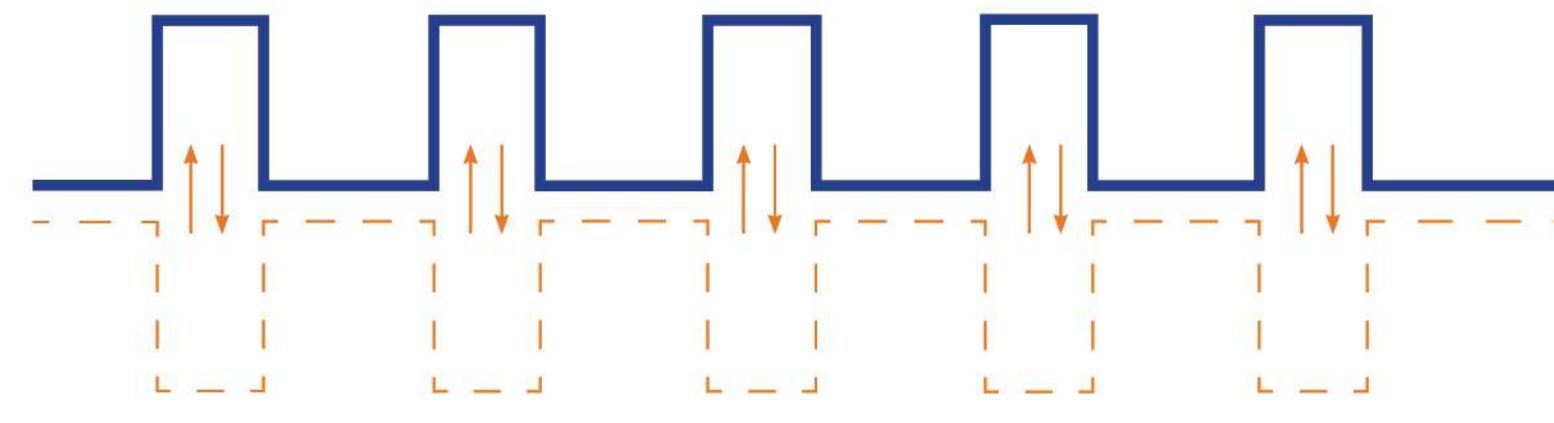

Plan - Zone of development



- lack of places to sit/stop

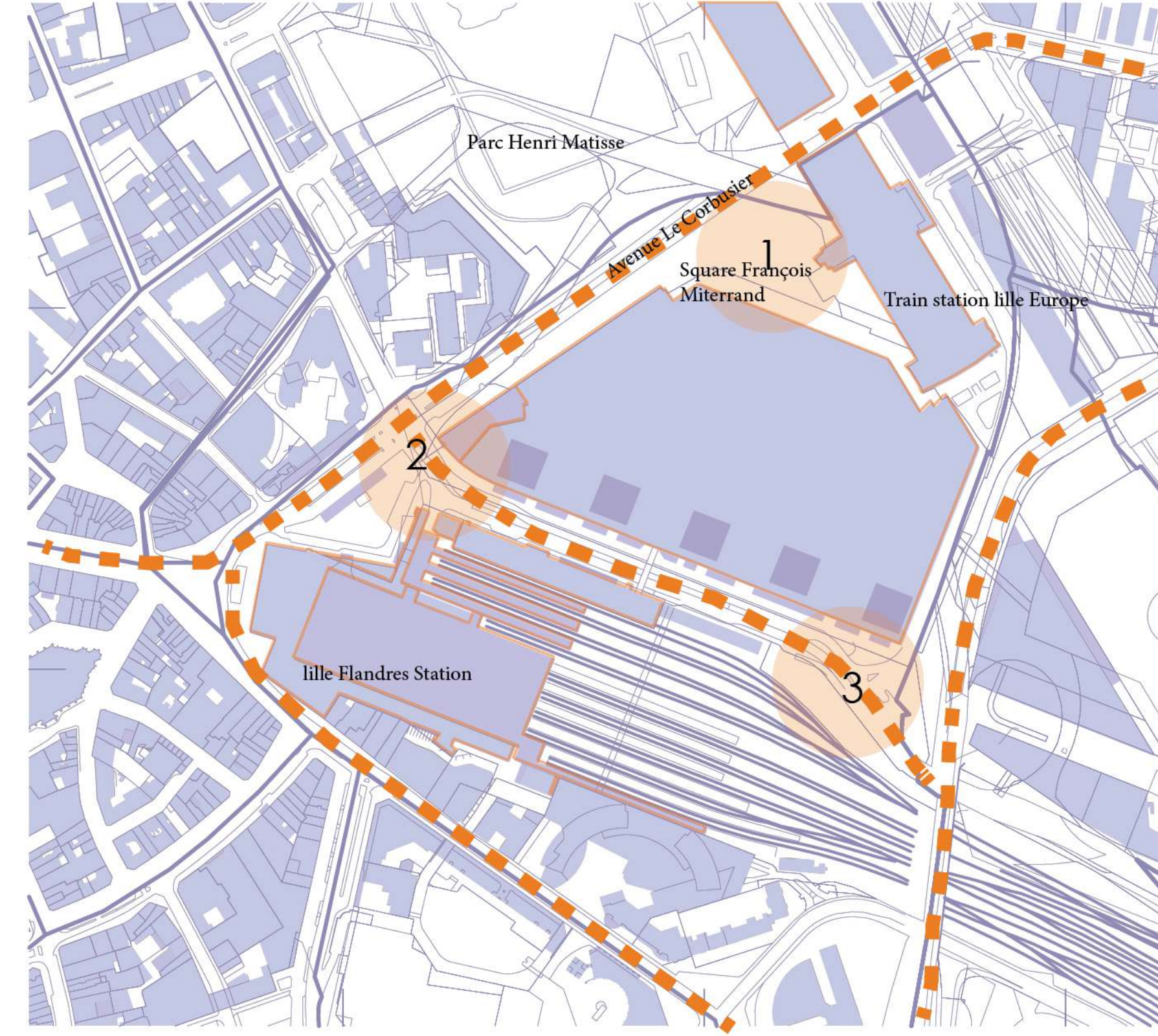

- lack of places to sit/stop

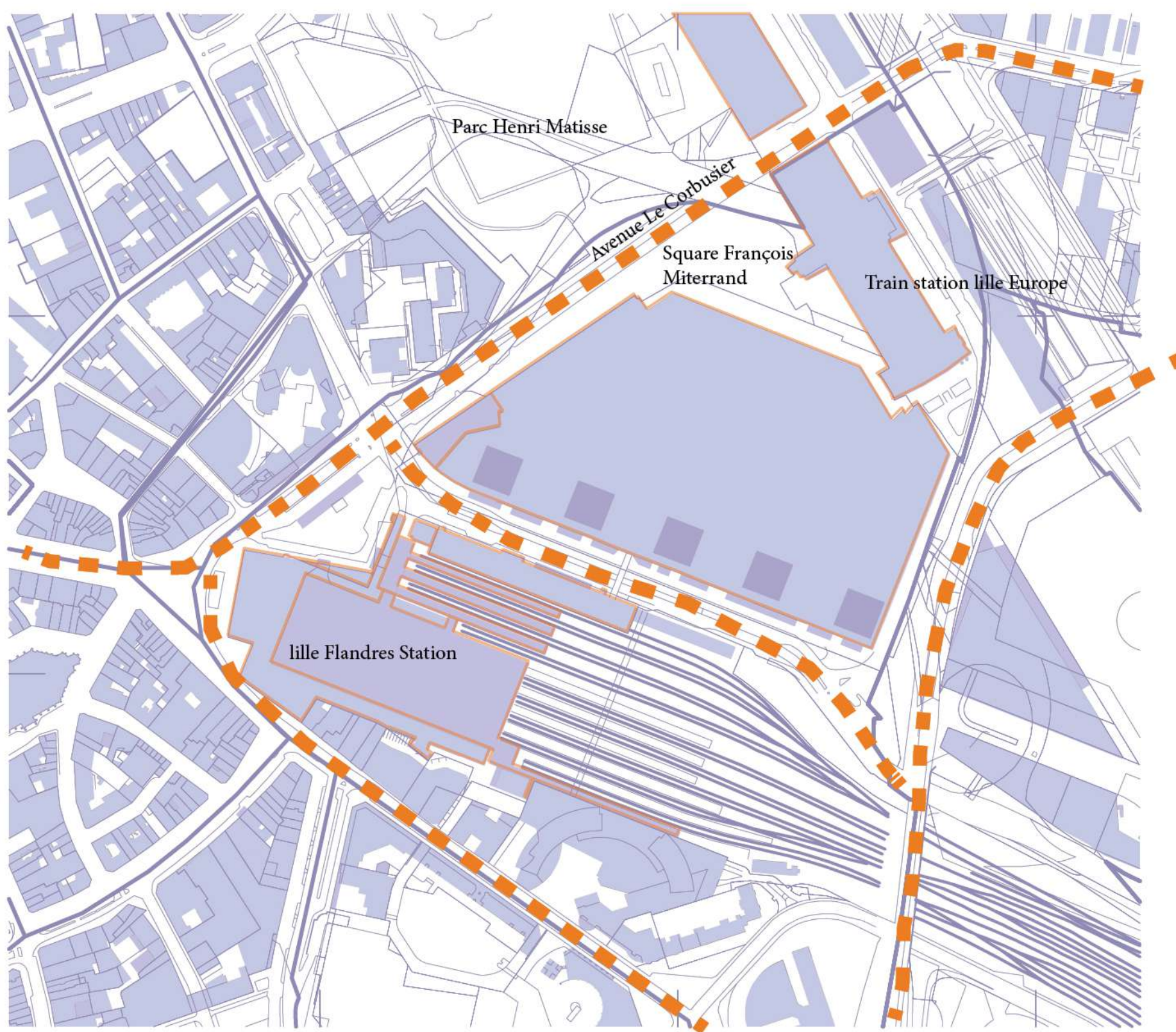

Plan - Circulation diagram



- lack of pedestrian areas
- omnipresence of car

Team 0c85252278

From small-scale innovation to urban transformation

The activities developed in the parking would propose a dynamic use of the space that can be beneficial not only to the residents of the city, but also to the passengers travelling from different countries and visiting Lille. People transferring from Gare Lille Europe to Gare Lille Flandres would be able to take a walk through the squares and actually enjoy a concert, a warm meal or an explanation of how mycelium works and it's produced.

For our team, the future of the carpark goes beyond the development of a specific programme, but rather spreads to questions related to use of those spaces and the engagement of the residents in local social economic questions.

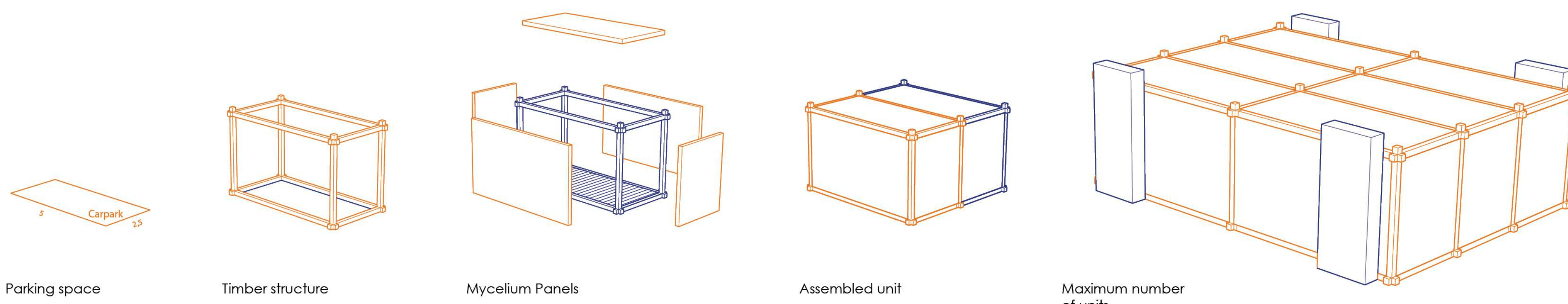

Parking space Timber structure Mycelium Panels Assembled unit Maximum number of units

Timber structures

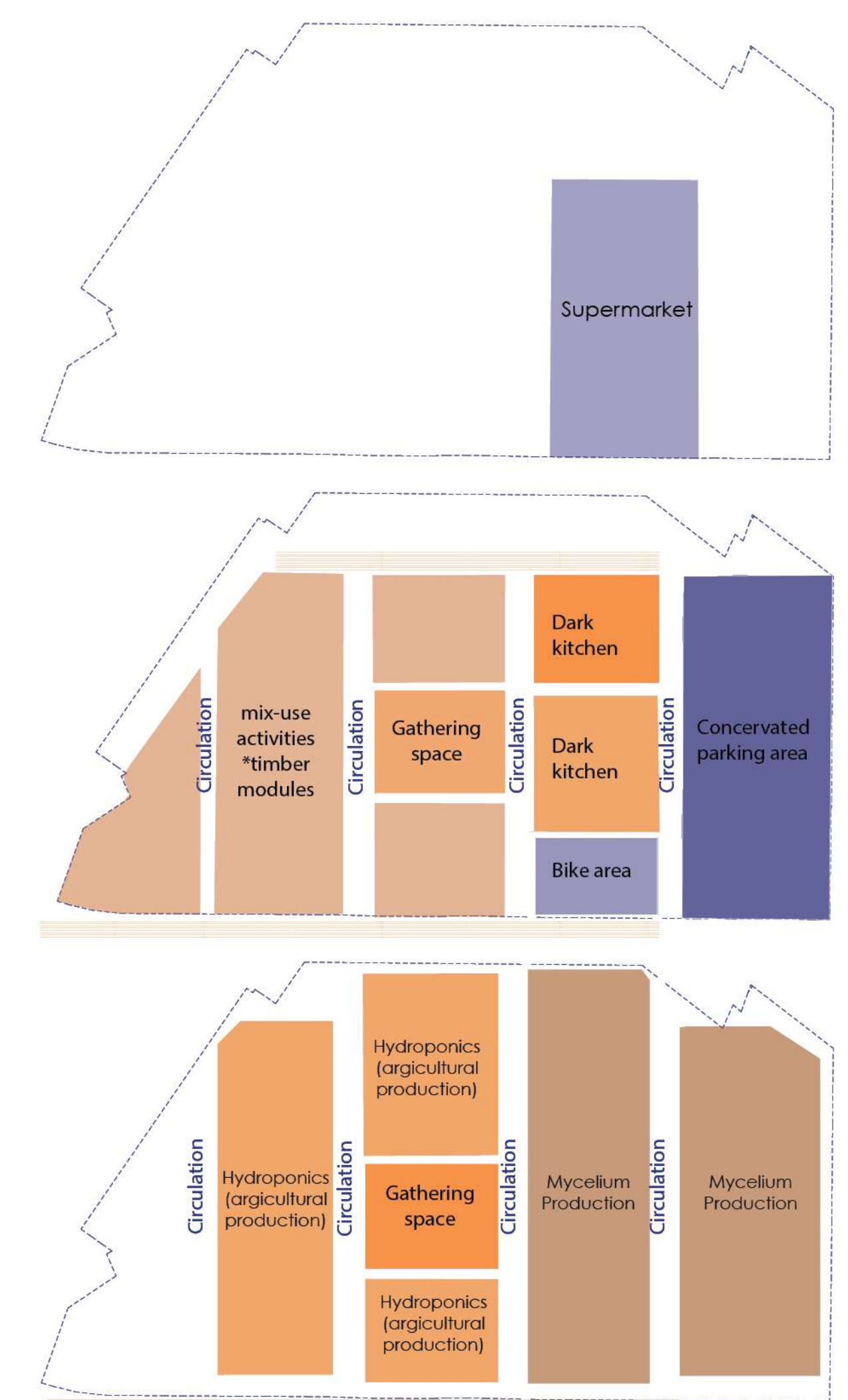

Program diagram



Main Section
Scale: 1/500

Team 0c85252278